

SPECIFICATIONS

PS1400

Powered Subwoofer

Built-In Amplifier Power Output
400 Watts

Sensitivity (2.83V/1m)
91dB

Frequency Response (-6dB)
28Hz to 130Hz

Crossover Frequency
130Hz

Low-Frequency Transducer
LE14H-3 14" Aquaplas™-cone woofer with rubber surround, 4" edge-wound copper voice coil, and cast-aluminum basket

Baffle
IsoPower™

Ports
2 FreeFlow™ flared

Terminals
5-Way, gold-plated binding posts

Dimensions (H x W x D)
19" x 20" x 15"
(483mm x 508mm x 381mm)
Plus grille and spike feet

Weight
80 lb (36kg)

PT800 Satellites

Recommended Amplifier Power Range
50 – 250 Watts

Nominal Impedance
8 Ohms

Sensitivity (2.83V/1m)
91dB

Frequency Response (-6dB)
80Hz to 22kHz

Crossover Frequencies
650Hz, 3200Hz

High-Frequency Transducer
1" Pure-titanium dome with rubber surround, shielded, with EOS™ waveguide

Midrange Transducer
4" Titanium inverted dome with rubber surround and cast-aluminum basket, shielded

Low-Frequency Transducer
8" Titanium-alloy inverted dome with rubber surround and cast-aluminum basket, shielded

Baffle
IsoPower™

Ports
None (sealed enclosure)

Network
Straight-Line Signal Path™ (SSP)

Terminals
5-Way, gold-plated binding posts

Dimensions (H x W x D)
24" x 13-1/2" x 6"
(610mm x 343mm x 152mm)
Plus grille

Weight
37 lb (17kg)

PC600 Center

Recommended Amplifier Power Range
50 – 250 Watts

Nominal Impedance
8 Ohms

Sensitivity (2.83V/1m)
91dB

Frequency Response (-6dB)
80Hz to 22kHz

Crossover Frequencies
800Hz, 3500Hz

High-Frequency Transducer
1" Pure-titanium dome with rubber surround, shielded, with EOS™ waveguide

Midrange Transducer
4" Titanium inverted dome with rubber surround and cast-aluminum basket, shielded

Low-Frequency Transducer
Dual, 6", titanium-alloy inverted domes with rubber surround and cast-aluminum basket, shielded

Baffle
IsoPower™

Ports
None (sealed enclosure)

Network
Straight-Line Signal Path™ (SSP)

Terminals
5-Way, gold-plated binding posts

Dimensions (H x W x D)
11-5/8" x 26-7/16" x 7-1/4"
(295mm x 672mm x 184mm)
Plus grille

Weight
32 lb (15kg)

All features and specifications are subject to change without notice.

* Trademarks of Dolby Laboratories.

DTS is a registered trademark of Digital Theater Systems, Inc.

OWNER'S GUIDE

PRODUCT LINE: **Performance™ Series**

MODELS: **PS1400, PT800, PC600**

DESIGN GOAL: Bring the thrill of live performance and movie sound to the home environment by calling on JBL's professional engineering leadership

TWEETER: 1-Inch, Pure-Titanium Dome with Rubber Surround, Mounted in EOS™ Waveguide

MIDRANGE: 4-Inch, Titanium Inverted Dome with Rubber Surround and Cast-Aluminum Basket

LOW-FREQUENCY: Titanium-Alloy Inverted Dome with Rubber Surround and Cast-Aluminum Basket in PT800 and PC600; 14-Inch Aquaplas™ with Rubber Surround, 4-Inch Edge-Wound Copper Voice Coil and Cast-Aluminum Basket in PS1400

PROFESSIONAL REFERENCE: Studio Monitor and Cinema Loudspeaker Series

JBL

**PRO SOUND
COMES
HOME™**

JBL Consumer Products
250 Crossways Park Drive, Woodbury, NY 11797 USA
8500 Balboa Boulevard, Northridge, CA 91329
800-336-4JBL (4525) (USA only)
www.jbl.com

©2001 JBL, Incorporated.

JBL is a registered trademark of JBL, Incorporated.

Part No. 336608-001

H A Harman International Company

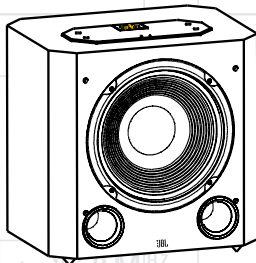
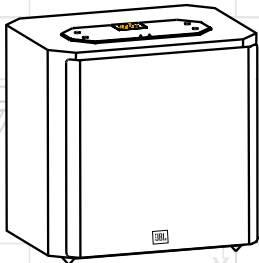
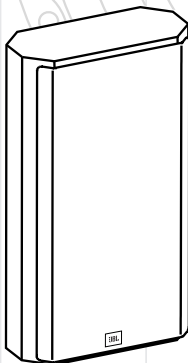
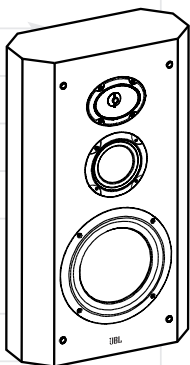
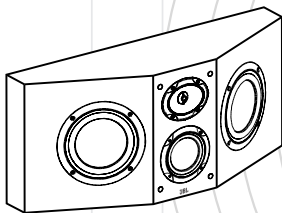

OWNER'S GUIDE

PRODUCT LINE: Performance™ Series

MODELS: PS1400, PT800, PC600

DESIGN GOAL: Bring the thrill of live performance and movie sound to the home environment by calling on JBL's professional engineering leadership

TWEETER: 1-Inch, Pure-Titanium Dome with Rubber Surround, Mounted in EOS™ Waveguide

MIDRANGE: 4-Inch, Titanium Inverted Dome with Rubber Surround and Cast-Aluminum Basket

LOW-FREQUENCY: Titanium-Alloy Inverted Dome with Rubber Surround and Cast-Aluminum Basket in PT800 and PC600; 14-Inch Aquaplas™ with Rubber Surround, 4-Inch Edge-Wound Copper Voice Coil and Cast-Aluminum Basket in PS1400

PROFESSIONAL REFERENCE: Studio Monitor and Cinema Loudspeaker Series

JBL

THANK YOU FOR CHOOSING JBL

For more than 50 years, JBL has been involved in every aspect of music and film recording and reproduction, from live performances to the recordings you play in your home, car or office.

We're confident that the JBL system you have chosen will provide every note of enjoyment that you expected – and that when you think about purchasing additional audio equipment for your home, car or office, you will once again choose JBL.

Please take a moment to complete the enclosed profile card. It enables us to keep you posted on our latest advancements, and helps us to better understand our customers and build products that meet their needs and expectations.

JBL Consumer Products

THE PERFORMANCE SYSTEM

The Performance System is an extremely high-performance speaker system intended for uses ranging from premium two-channel stereo all the way to 5.1, 6.1 or 7.1 multi-channel home-theater applications. The system is modular and consists of only three system elements:

- A PS1400 powered subwoofer module incorporating a 14" driver and internal 400-watt class D amplifier.
- A PT800 tower module which contains an 8" mid-bass driver, a 4" midrange driver and a 1" dome tweeter with integral waveguide.
- A PC600 center module which contains dual 6" drivers and the same midrange and tweeter elements as the tower.

The acoustic behavior of the PT800 tower and PC600 center

has been matched, giving the added system flexibility of using either PT800 towers or PC600 centers at any of the five, six or seven speaker locations around the room.

The system is intended for room sizes of up to 3500 cubic feet with two subwoofers. If a larger room is being used, it is suggested that additional subwoofer modules be used. Almost any home installation can be accommodated by the use of multiple modules.

The PT800 tower and PS1400 subwoofer can be docked (stacked), resulting in a traditional floorstanding speaker system that can be used in the front or surround speaker positions. This system can be used passively, or in a bi-amp mode by using the

crossover capabilities of a high-quality AV receiver or separates. The PS1400 subwoofers can also be used as traditional units placed around the room with the PT800 towers and/or PC600 centers being stand-, wall-, or bookshelf-mounted. Both the PT800 and PC600 speakers come with wall-mounting brackets.

Important Note: Do not send a full-range amplified signal directly to the PT800 tower module. The PT800's are not designed to reproduce low bass without a PS1400 powered subwoofer. For optimum performance, the PT800 should only receive signals crossed over at 80Hz and above.

Declaration of Conformity



We, Harman Consumer International
2, route de Tours
72500 Chateau-du-Loir
France

declare in own responsibility, that the passive loudspeakers described in this owner's manual are in compliance with technical standards:
EN 50081-1:1992
EN 50082-1:1992

Steen Michaelsen
Harman Consumer International
Chateau-du-Loir, France, 2/01

This declaration applies to models PC600 and PT800 only. Information regarding model PS1400 is included separately with that model only.

INCLUDED

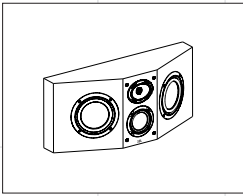

One PC600 Center Speaker

OR

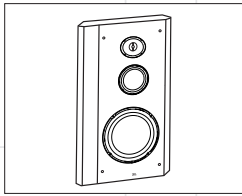

One PT800 Satellite Speaker

OR

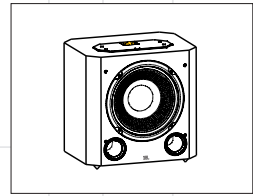

One PS1400 Powered Subwoofer

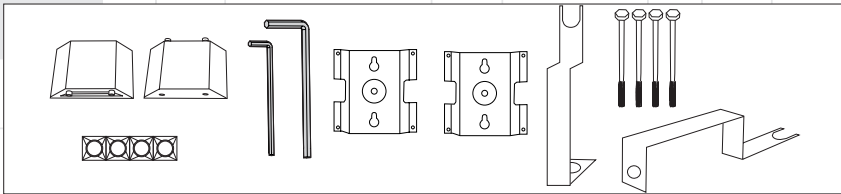

Accessories carton containing:

For PS1400: 2 gold jumper bars to connect PS1400 speaker outputs to PT800 inputs; 2 mounting pillars; 4 long hex bolts; 1 Allen wrench.

For PT800 and PC600: 4 rubber pads for use when modules are wall-mounted; 2 metal wall-mounting brackets for secure wall-mounting; 1 Allen wrench.

SPEAKER PLACEMENT

Important Note for PS1400 Placement: The PS1400 features spiked feet for optimum acoustic performance. However, spikes can damage certain types of floors, such as hardwood. In such instances, place furniture coaster pads, available from any hardware store, between the feet and the floor.

5.1-Channel System

Front Speakers

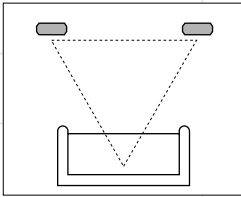

Center-Channel Speaker

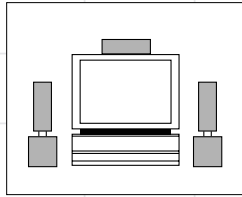

Surround Speakers

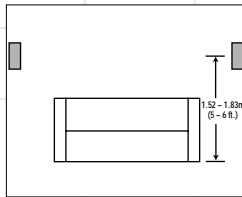
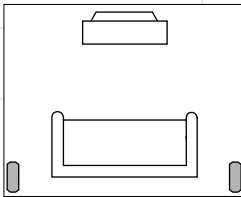

The front speakers should be placed the same distance from each other as they are from the listening position. The PT800 towers should be placed with tweeters at about the same height from the floor as the listeners' ears will be, or they may be angled toward the listeners. This applies whether or not the PT800 is docked with the PS1400 subwoofer.

The PC600 center-channel speaker should be placed slightly behind the front left and right speakers, and no more than two feet above or below the tweeters of the left

and right speakers. It is often convenient to set the center speaker on top of the television set, as shown in the drawing.

The two surround speakers should be placed slightly behind the listening position and, ideally, should face each other and be at a level higher than the listeners' ears. If that is not possible, they may be placed on a wall behind the listening position, facing forward. The surround speakers should not call attention to themselves. Experiment with their

placement until you hear a diffuse, ambient sound accompanying the main-program material heard in the front speakers.

If you are not docking the PT800 tower and PS1400 subwoofer modules:

The low-frequency material reproduced by the subwoofer is mostly omni-directional, and this speaker may be placed in a convenient location in the room. However, the best reproduction of bass will be heard when the subwoofer is placed in a corner along the same wall as the front speakers. Experiment with subwoofer placement by temporarily placing the subwoofer in the listening position and moving around the room until the bass reproduction is best. Place the subwoofer in that location.

6.1-Channel System

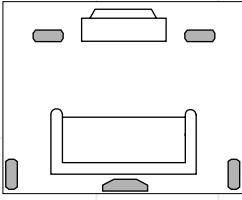

A 6.1-channel system will consist of a 5.1-channel configuration, as shown on page 4, with the addition of a rear center speaker placed midway between the two surround speakers, and further to the rear than the

surrounds. The rear center speaker will no more call attention to itself than the surround speakers.

7.1-Channel System

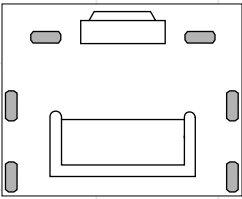

Some newer surround-sound formats utilize left and right surround channels that are used for side fill, in addition to the left and right rear channels found in 5.1 systems. Place the left and right surround speakers on the

sides of the room, at or in front of the listening position, facing each other.

MOUNTING OPTIONS

Stacking the PT800 Tower on Top of the PS1400 Subwoofer

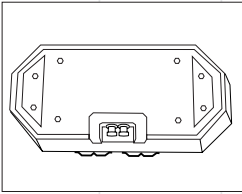

Figure 1

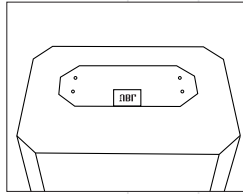

Figure 2

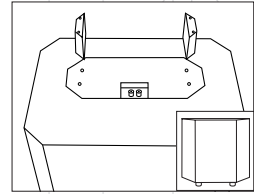

Figure 3

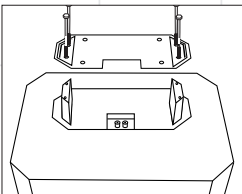

Figure 4

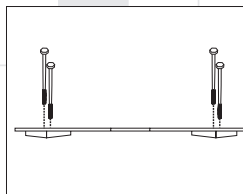

Figure 4a

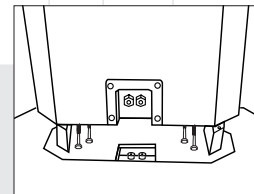

Figure 5

1. Gently place the PT800 tower upside down on a padded surface, and remove the 4 bolts holding the metal plate on the bottom of the tower using the included Allen wrench. (Figure 1)

2. Lift the metal plate off of the speaker (you may need to insert one end of the Allen wrench into an empty screw

hole and pull the plate upwards) and set it aside, with the four bolts.

3. Place the PS1400 subwoofer in the desired location, as described in the Speaker Placement section, and remove the 4 Allen head bolts from the mounting plate on top of the subwoofer. Put these bolts in a safe place for future use, should you decide to change the placement of the modules, or if you need to repack the PS1400 for moving or other purposes. Do not remove the mounting plate from the PS1400 subwoofer. (Figure 2)

4. Place the two trapezoidal tower supports on the subwoofer mounting plate with the larger flat surfaces facing inwards and the protrusions inserted into the screw holes in the mounting plate. (Figure 3)

5. Place the metal plate that you removed from the bottom of the tower (in Step 1) on top of the tower supports. The protruded areas should face downward and rest on top of the tower supports, with the screw holes lined up, and the notch for the PT800's terminal cup should be to the rear. (Figures 4 and 4a)

6. Secure the assembly using the 4 long (3-1/2-inch) hex bolts provided in the accessories kit included with the PS1400 module.

7. Carefully place the tower on the metal plate and secure it by screwing the 4 hex bolts removed in Step 1 through the bottom of the mounting plate and up into the tower module. Remember that the bolts must be screwed in clockwise from the point of view looking upwards at the bottom of the metal plate, and that this may be counter to your intuition. (Figure 5)

Wall-Mounting the PT800 Tower or the PC600 Center

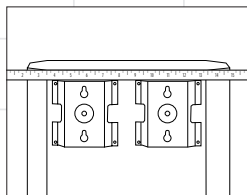
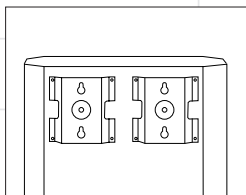

NOTICE: Important Safety Notes

- Proper selection of mounting hardware and installation of the wall and/or corner brackets are the responsibility of the customer.
- This product is not intended for ceiling mounting.

Remove the two hex bolts on the back of the cabinet. Attach the metal hanging supports using the same screws. Before tightening the bolts, lay a flat rod, carpenter's level, or equivalent, across the top of the supports. This will ensure that they are level. Tighten the bolts securely to maintain an airtight speaker cabinet.

Two Number 10 round head or pan head screws should be used per loudspeaker; only the top keyhole of each bracket will be used. The screwhead should be between 3/8 inch and 13/32 inch in diameter, and the screw should be at least 2 inches in length. When installing screws through drywall, always use properly selected wall anchors.

Attach two pieces of the four self-adhesive rubber pads that came with the PT800 to the back of the enclosure in the two bottom corners so that the cabinet is spaced evenly from the wall.

Select a suitable mounting location on a wall. (The ceiling is not a suitable mounting location.)

Drill two pilot holes, appropriately sized for the specific self-tapping screw or wall-anchor that you will be using. The holes should be 5-1/4 inches apart for the PT800 and 12-7/8 inches apart for the PC600. The holes should be 1-1/4 inch below where you want the top of the enclosure to be positioned.

Wall Mounting (Continued)

Install the two screws into either a wooden wall-stud or anchor, and tighten them until the back of each screwhead is about 1/8 inch from the wall.

Install the loudspeaker by slowly moving the cabinet

toward the screws so that the screwheads clear the larger circular portion of the top two keyholes of the two brackets. Once both screwheads have entered the keyholes, the loudspeaker should gently be

lowered onto the screw shafts. Check that the loudspeaker is firmly locked onto the screws by gently pulling the speaker down and forward.

Corner-Mounting the PT800 Tower

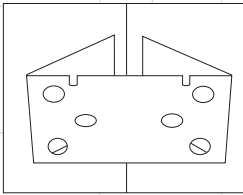

If desired, you may mount the PT800 towers in the corners of the room using the optional PCM800 corner-mount bracket. PCM800 corner-mounting kits are available separately from your JBL dealer.

NOTICE: Important Safety Notes

- Proper selection of mounting hardware and installation of the wall and/or corner brackets are the responsibility of the customer.
- This product is not intended for ceiling mounting.

Six Number 10 round head or pan head screws should be used per loudspeaker. The screw head should be between 3/8 inch and 13/32 inch in diameter, and the screw should be at least 2 inches in length. When installing screws through drywall, always use properly selected wall anchors.

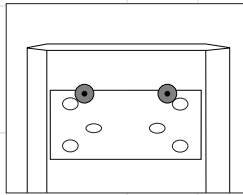

Attach two pieces of the four self-adhesive rubber pads that came with the PT800 to the angled surfaces of the enclosure near the bottom to prevent the speaker from rattling against the wall and to allow a firm fit.

Select a suitable mounting location in a wall corner. (The ceiling is not a suitable mounting location.)

Hold the wall bracket against the wall with the U-shaped cutouts at the top. Make sure that it's level and 3/4 inch below where you want to have the top of your PT800 enclosure positioned. Mark the center of each of the six mounting holes using a pencil or sharp implement. Remove the bracket and drill six pilot holes as required for your wood screws or anchors. Securely fasten the

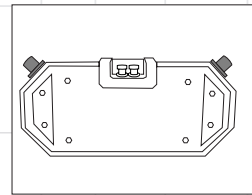

bracket to the wall. You have access to the wall screws via the six large holes on the front face of the bracket.

Loosen, but do not remove, the two hex bolts on the back of the PT800 speaker cabinet. Back the screws out until the head is about 1/4 inch from the enclosure. Install the loudspeaker by slowly lowering the cabinet towards the U-shaped cutouts at the front top surface of the PCM800 bracket so that the hex bolt shafts rest in the cutouts. Check that the speaker is level, then tighten the hex bolts. Check that the loudspeaker is firmly locked onto all screws by gently pulling the speaker down and forward.

SPEAKER CONNECTIONS

Subwoofer Controls (PS1400 Only)

1 On/Auto Switch – When left in the “Auto” position, the PS1400 subwoofer will automatically turn on or go into standby mode, depending on whether it detects an audio signal. When no signal is being sent, the PS1400 will remain in standby mode. When it senses an audio signal, it will automatically turn itself on and begin playing. If the PS1400 does not sense a signal for about twenty minutes, it will switch itself into standby mode. When this switch is left in the “On” position, the PS1400 will remain on, whether or not program material is playing.

2 LF Crossover Switch – This switch is used to engage the PS1400’s internal crossover when it is stacked with the PT800 tower module, and when no external crossover is being used. In the “Normal” position, the internal crossover is engaged, and provides an electronic 130Hz crossover for the subwoofer which precisely matches the passive 130Hz crossover point of the output terminal to the PT800. The crossover is precision-designed to create a smooth, integrated floorstanding speaker system when the PS1400 and PT800 are stacked.

In the “Separated” position, the PS1400 provides an electronic 300Hz rolloff for the subwoofer, which should be augmented by the low-pass crossover in the external audio/video receiver or processor. In this mode, the PT800, whether or not it is

stacked with the PS1400, should be given only a high-passed amplifier signal. That signal should be crossed over at 80Hz.

3 LF Level Control – This control allows you to adjust the level of the subwoofer within a range of +/- 5dB. Start with the control positioned at 0dB, which is flat (neutral bass level). If bass response is unsatisfactory, due to either your room acoustics or as a matter of taste, experiment with this control until the desired bass level is achieved. This control only affects all information being received by the speaker-level input.

4 Polarity (Phase) Switch – Use the “Normal” position whenever the PS1400 and PT800 are stacked and the internal crossover is used. It should also be used when an external crossover is used and all amplifier channels are in phase.

The “Reverse” position may be used when the PS1400 and PT800 are separated, and due to wave cancellation, bass response is improved in this position. “Reverse” may also be selected when different amplifiers are used that have different polarity configurations.

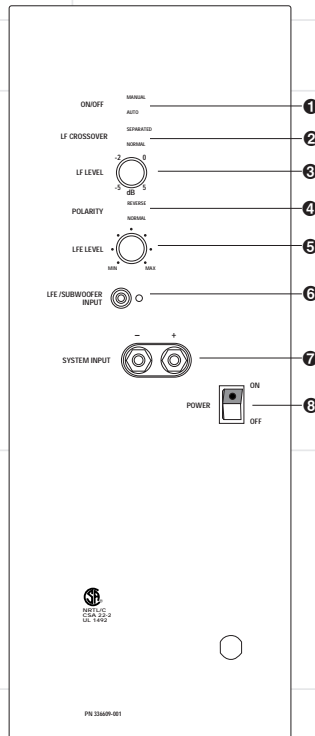

5 LFE Level Control – This control only affects the signal sent to the LFE input. Adjust the LFE level by starting with the level controls on both PS1400 modules in the Minimum position. With 5.1, 6.1 or 7.1 source material playing, advance the LFE Level controls on both PS1400s slowly until the desired amount of effects channel is present. The normal position for this control is full clockwise, with LFE adjustments being made via the level adjustments on your processor. We have provided this control because the LFE output level of AV receivers and processors can vary from manufacturer to manufacturer.

If you are using the third or fourth configurations, where

the main speakers are configured as “Small” and all bass information is being sent to the LFE inputs of the PS1400s, the LFE Level control will operate on all low- frequency information, and not just for the .1 channel effects.

6 LFE/Subwoofer Input – This jack accepts either an LFE or line-level output from the receiver or processor.

7 System Input – These binding posts accept a full-range, amplified (speaker-level) output from the receiver or amplifier. This input should be used whenever the PS1400 and PT800 modules will be stacked and the internal crossover used to form an integrated floorstanding speaker system. This input

should be used in that configuration even if the LFE input will also be used.

8 Power – This is the main power switch, which must be turned on for the amplifier and electronic internal crossover to function. If you will be away from home for an extended period of time, or if the PS1400 will not be used, turn this switch off to conserve electricity.

General Connection Information

Separate and strip the ends of the speaker wire (not supplied) as shown. Speakers and electronics terminals have corresponding (+) and (-) terminals. Most manufacturers of speakers and electronics, including JBL, use red to denote the (+) terminal and black for the (-) terminal. The (+) lead of the speaker wire is sometimes noted with a stripe or other demarcation. It is important to connect both speakers identically: (+) on the speaker to (+) on the amplifier

and (-) on the speaker to (-) on the amplifier. Wiring “out of phase” results in thin sound, weak bass and a poor stereo image.

With the advent of multi-channel surround-sound systems, connecting all of the speakers in your system with the correct polarity remains equally important in order to preserve the proper ambience and directionality of the program material.

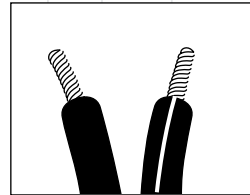

CONNECTIONS AND SETTINGS

There are four possible configurations for connecting the PT800 tower and PS1400 subwoofer modules. The PC600

center is always connected directly to the speaker-level outputs of the receiver or amplifier.

Stacked, With Speaker-Level Input to PS1400 and Internal High-Pass Signal Output to PT800

Use this installation method with the PT800 and PS1400 stacked.

By using the PS1400's internal crossover to process the full range output of your receiver or amplifier, the Performance speakers can behave as a single full-range system and produce the highest quality of sound reproduction that makes the best use of each transducer component of each module.

Do not use the PS1400's internal crossover and speaker-level outputs unless the PS1400 and PT800 are stacked. If the PT800 is placed separately – on the wall, on a shelf or on a stand – you must use your receiver or processor's crossover, which should be set to 80Hz. The reason for this is that the PS1400's internal crossover is set at 130Hz, and was custom-designed around the precise location of the PT800 module on top of the subwoofer.

This installation method can be used for non-digital surround-sound formats, such as Dolby* Pro Logic*, where the receiver or processor does not have a subwoofer output or a volume-controlled preamp (line-level) output.

1. Configure the receiver/processor for "Large" speakers for the left and right channels.
2. Configure the receiver/processor for "Subwoofer Off".
3. Configure the receiver/processor for "Small" for the center and rear channels.
4. Check the owner's guide for your receiver or amplifier to make sure that the main speaker terminals will output a full-range amplified signal. Connect your receiver or amplifier's left and right speaker terminals to the binding posts marked "System Input" 7 on your corresponding left and right PS1400 subwoofer modules.
5. Set the PS1400's crossover switch 2 to the "Normal" position. This will cause the PS1400 to provide an electronic 130Hz crossover for the subwoofer that matches the passive 130Hz crossover point at the output to the PT800 tower.
6. Set the Polarity (phase) switch 4 to Normal, since all amplifier channels will be in phase, and in the stacked configuration, sound-wave cancellation will not be an issue.

7. Remove the JBL logo plate from the mounting plate on top of the PS1400 by gently prying it upwards. This will expose the binding post output terminals that will provide the signal for the PT800 module. It is easiest to connect the gold jumper bars between the terminals on the top of the PS1400 and the terminals on the rear of the PT800 by completely unscrewing the binding post collars first. Insert the closed loop at one end of the jumper bar over the PS1400 output terminal, and insert the open end of the bar around the PT800's input. Screw the collars back onto their respective posts.

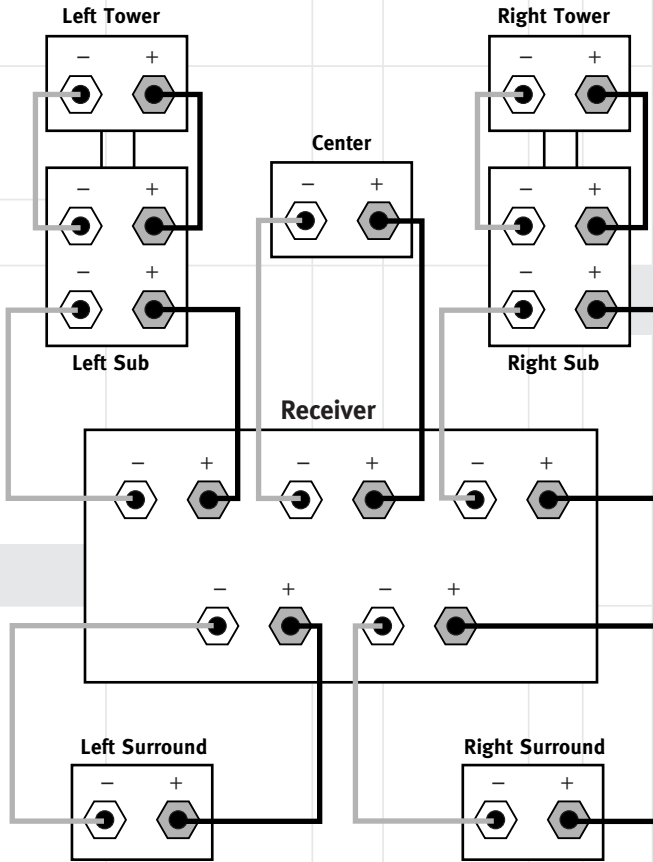

Note: You may, if desired, use stacked PS1400 and PT800 modules in the surround speaker positions. These should be wired the same way as shown above for the front speakers. If you choose this configuration, change the setting on your receiver/processor for the rear channels from "Small" to "Large".

Stacked, With LFE and Speaker-Level Inputs to PS1400 and Internal High-Pass Signal Output to PT800

Use this installation method with the PT800 and PS1400 stacked.

By using the PS1400's internal crossover to process the full range output of your receiver or amplifier, the Performance speakers can behave as a single full-range system and produce the highest quality of sound reproduction that makes the best use of each transducer component of each module. In addition, the LFE (low-frequency effects) channel provided by some digital sources can be mixed in with the low-frequency signal to provide effects that add excitement and realism to movie soundtracks, musical performances or other materials.

Do not use the PS1400's internal crossover and speaker-level outputs unless the PS1400 and PT800 are stacked. If the PT800 is placed separately – on the wall, on a shelf or on a stand – you must use your receiver or processor's crossover, which should be set to 80Hz. The reason for this is that the PS1400's internal crossover is set at 130Hz, and was custom-designed around the precise location of the PT800 module on top of the subwoofer.

This installation method should be used for digital surround-sound formats, such as Dolby Digital or DTS®, where the receiver or processor has a subwoofer output or a volume-controlled preamp (line-level) output.

1. Configure the receiver/processor for “Large” speakers for the left and right channels.
2. Configure the receiver/processor for “Subwoofer On.”
3. Configure the receiver/processor for “Small” for the center and rear channels.
4. Check the owner's guide for your receiver or amplifier to make sure that the main speaker terminals will output a full-range amplified signal. Connect your receiver or amplifier's left and right speaker terminals to the binding posts marked “System Input” ⑦ on your corresponding left and right PS1400 subwoofer modules.
5. Set the PS1400's crossover switch ② to the “Normal” position. This will cause the PS1400 to provide an electronic 130Hz crossover for the subwoofer that matches the passive 130Hz crossover point at the output to the PT800 tower.
6. Set the Polarity (phase) switch ④ to Normal, since all amplifier channels will be in phase, and in the stacked configuration, sound-wave cancellation will not be an issue.
7. Connect the receiver/processor's LFE or subwoofer output to the LFE Input ⑥ on your left and right PS1400 subwoofer modules. If your receiver/processor has only one output jack, use a Y-connector (not included). Plug the male end of the Y-connector into your

receiver/processor's subwoofer output jack, and connect each of the two female ends to separate RCA-type patch cords, then plug the RCA-type patch cords into the LFE inputs of the PS1400 modules.

8. Remove the JBL logo plate from the mounting plate on top of the PS1400 by gently prying it upwards. This will expose the binding post output terminals that will provide the signal for the PT800 module. It is easiest to connect the gold jumper bars between the terminals on the top of the PS1400 and the terminals on the rear of the PT800 by completely unscrewing the binding post collars first. Insert the closed loop at one end of the jumper bar over the PS1400 output terminal, and insert the open end of the bar around the PT800's input. Screw the collars back onto their respective posts.

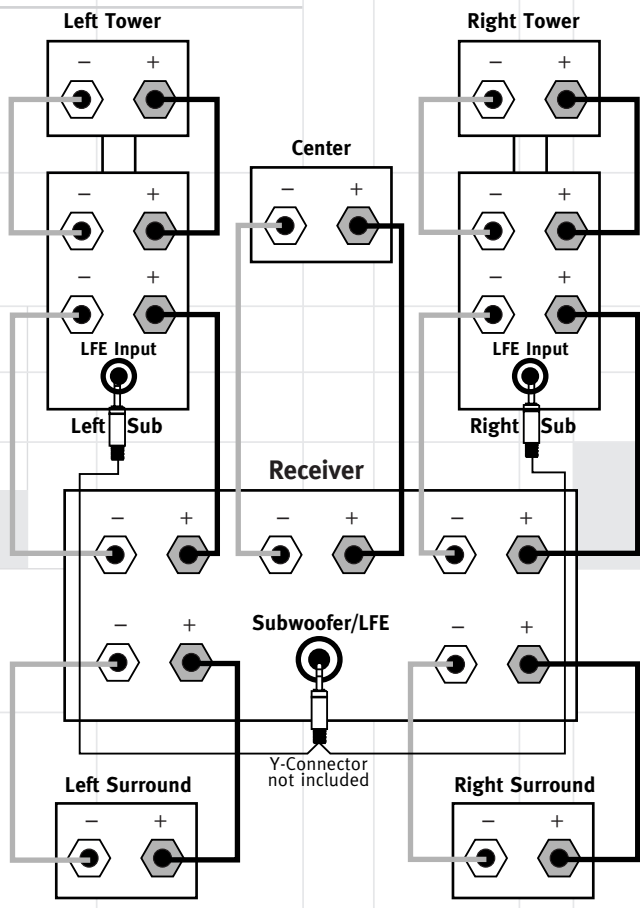

Note: You may, if desired, use stacked PS1400 and PT800 modules in the surround speaker positions. These should be wired using the same speaker-level connections as shown above for the front speakers but without using the subwoofer/LFE connections. If you choose this configuration, change the setting on your receiver/processor for the rear channels from "Small" to "Large".

Stacked, With LFE Input to PS1400 and Externally Crossed-Over Input to PT800

Use this installation method with the PT800 and PS1400 stacked.

We do not recommend sending a full-range signal to the PT800 module. Check the owner's guide for your receiver or amplifier and processor, and follow the directions to obtain a high-pass 80Hz signal at the left and right speaker outputs.

The LFE (low-frequency effects) channel provided by some digital sources can be sent to the PS1400 module to provide effects that add excitement and realism to movie soundtracks, musical performances or other materials.

This installation method should be used for digital surround-sound formats, such as Dolby Digital or DTS, where the receiver or processor has a subwoofer output or a volume-controlled preamp (line-level) output.

1. Configure the receiver/processor for "Small" speakers for the left and right channels.
2. Configure the receiver/processor for "Subwoofer On".

3. Configure the receiver/processor for "Small" for the center and rear channels.

4. Check the owner's guide for your receiver or amplifier to make sure that the main speaker terminals will output a high-pass amplified signal that is crossed over at 80Hz. Connect your receiver or amplifier's left and right speaker terminals to the speaker binding posts on the corresponding left and right PT800 modules. Be sure that the JBL logo plate is installed over the output terminals on the top of the PS1400 subwoofer module.

5. Set the PS1400's crossover switch **2** to the "Separated" position. This will cause the PS1400 to provide an electronic 300Hz rolloff for the subwoofer that should be augmented by the low-pass crossover in the receiver or processor.

6. Set the Polarity (phase) switch **4** to Normal, since all amplifier channels will be in phase, and in the stacked configuration, sound-wave cancellation will not be an issue.

7. Connect the receiver/processor's LFE or subwoofer output to the LFE input **6** on your left and right PS1400 subwoofer modules. If your receiver/processor has only one output jack, use a Y-connector (not included). Plug the male end of the Y-connector into your receiver/processor's subwoofer output jack, and connect each of the two female ends to separate RCA-type patch cords, then plug the RCA-type patch cords into the LFE inputs of the PS1400 modules.

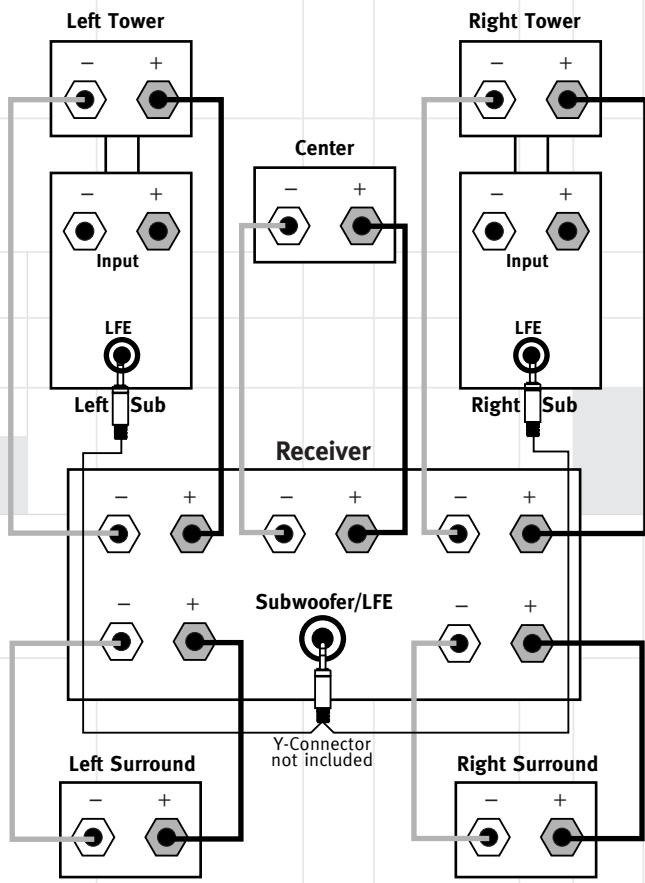

Separated, With LFE Input to PS1400 and Externally Crossed-Over Input to PT800

Use this installation method with the PT800 and PS1400 separated; that is, the PT800 module mounted on a wall, shelf or stand.

We do not recommend sending a full-range signal to the PT800 module. Check the owner's guide for your receiver or amplifier and processor, and follow the directions to obtain a high-pass 80Hz signal at the left and right speaker outputs.

The LFE (low-frequency effects) channel provided by some digital sources can be sent to the PS1400 module to provide effects that add excitement and realism to movie soundtracks, musical performances or other materials.

This installation method should be used for digital surround-sound formats, such as Dolby Digital or DTS, where the receiver or processor has a subwoofer output or a volume-controlled preamp (line-level) output.

1. Configure the receiver/processor for "Small" speakers for the left and right channels.

2. Configure the receiver/processor for "Subwoofer On".

3. Configure the receiver/processor for "Small" for the center and rear channels.

4. Check the owner's guide for your receiver or amplifier to make sure that the main speaker terminals will output a high-pass amplified signal that is crossed over at 80Hz. Connect your receiver or amplifier's left and right speaker terminals to the speaker binding posts on the corresponding left and right PT800 modules. Be sure that the JBL logo plate is installed over the output terminals on the top of the PS1400 subwoofer module.

5. Set the PS1400's crossover switch **2** to the "Separated" position. This will cause the PS1400 to provide an electronic 300Hz rolloff for the subwoofer that should be augmented by the low-pass crossover in the receiver or processor.

6. Set the Polarity (phase) switch **4** to Normal, but experiment with switching it to Reverse and then select the position that produces the best bass reproduction.

7. Connect the receiver/processor's LFE or subwoofer output to the LFE input **6** on your left and right PS1400 subwoofer modules. If your receiver/processor has only one output jack, use a Y-connector (not included). Plug the male end of the Y-connector into your receiver/processor's subwoofer output jack, and connect each of the two female ends to separate RCA-type patch cords, then plug the RCA-type patch cords into the LFE inputs of the PS1400 modules.

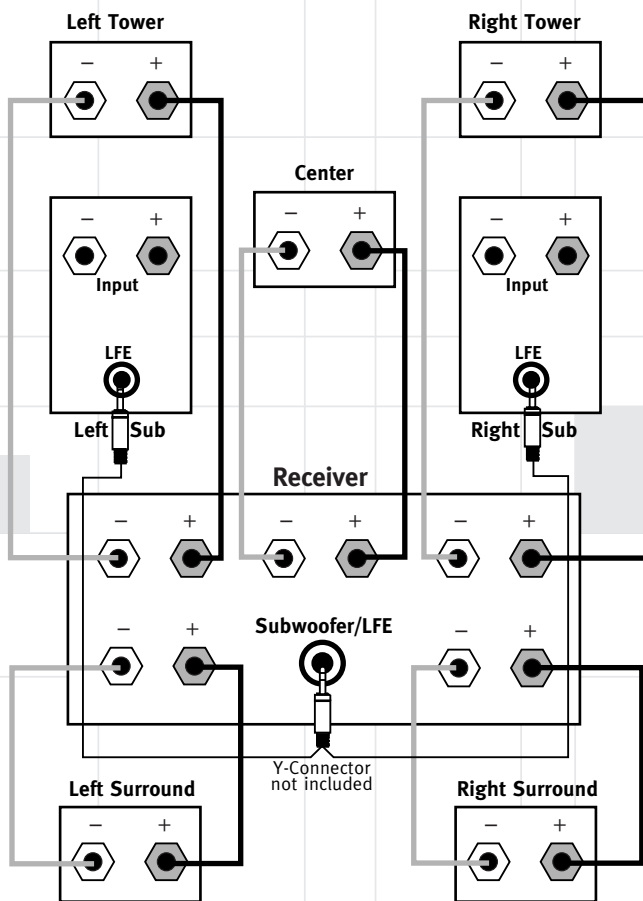

TROUBLESHOOTING

If there is no sound from any of the speakers:

- Check that receiver/amplifier is on and a source is playing.
- Check that the PS1400 is plugged in and its Power switch **Ⓑ** is switched on.
- Check all wires and connections between receiver/amplifier and speakers. Make sure all wires are connected. Make sure none of the speaker wires are frayed, cut or punctured.
- Review proper operation of your receiver/amplifier.

If there is no sound coming from one speaker:

- Check the "Balance" control on your receiver/amplifier.
- Check all wires and connections between receiver/amplifier and speakers. Make sure all wires are connected. Make sure none of the speaker wires are frayed, cut or punctured.
- In Dolby Digital or DTS modes, make sure that the receiver/processor is configured so that the speaker in question is enabled.

If there is no sound from the center speaker:

- Check all wires and connections between receiver/amplifier and speaker. Make sure all wires are connected. Make sure none of the speaker wires are frayed, cut or punctured.

- If your receiver/processor is set in Dolby Pro Logic mode, make sure the center speaker is not in phantom mode.

- If your receiver/processor is set in Dolby Digital or DTS mode, make sure the receiver/processor is configured so that the center speaker is enabled.

If the system plays at low volumes but shuts off as volume is increased:

- Check all wires and connections between receiver/amplifier and speakers. Make sure all wires are connected. Make sure none of the speaker wires are frayed, cut or punctured.
- If more than one pair of main speakers is being used, check the minimum impedance requirements of your receiver/amplifier.

If there is low (or no) bass output:

- Make sure the connections to the left and right "Speaker Inputs" have the correct polarity (+ and -).
- Make sure the PS1400 is plugged into an active electrical outlet.
- Make sure the Power switch **Ⓑ** is on.
- In Dolby Digital or DTS modes, make sure your receiver/processor is configured so that the subwoofer and LFE output are enabled.

- Adjust the Polarity switch **Ⓓ** if the PS1400 and PT800 are not stacked, or if they are stacked but an external crossover is being used.

- Adjust the LF Level control **Ⓒ**.

- If the LFE input is in use, adjust the LFE Level control **Ⓔ**.

If there is no sound from the surround speakers:

- Check all wires and connections between receiver/amplifier and speakers. Make sure all wires are connected. Make sure none of the speaker wires are frayed, cut or punctured.
- Review proper operation of your receiver/amplifier and its surround-sound features.
- Make sure the movie or TV show you are watching is recorded in a surround-sound mode. If it is not, check to see if your receiver/amplifier has other surround modes you may use.
- In Dolby Digital or DTS modes, make sure your receiver/processor is configured so that the surround speakers are enabled.
- Review the operation of your DVD player and the jacket of your DVD to make sure that the DVD features the desired Dolby Digital or DTS mode, and that you have properly selected that mode using both the DVD player's menu and the DVD disc's menu.



Staple sales invoice here.